

myFAX Reference Guide for Inter-operation with PBX V1.0

How is work?

The myFAX fax server is a turnkey solution that connects to an analog port(s) of a PBX capable of DID to DTMF conversion. Many PBX's and Key telephone systems use Direct Inward Dialing(DID), Digital DID, or Dialed Number Identification Service(DNIS) provided by a T1 or E1 for direct dialing to internal extensions. Unused numbers from these lines can be used for fax numbers, providing employees with their own individual fax number.

Every network user is assigned an individual fax phone number. The retaining digits of that number correspond to the individual's fax extension. Senders simply dial the individual's fax telephone number (no special procedures are required). When a call is received, the PBX converts the number into DTMF tones and sends it to the fax server. The fax server answers the call, receives the fax. Once received, users can view, print or forward the fax to other user.

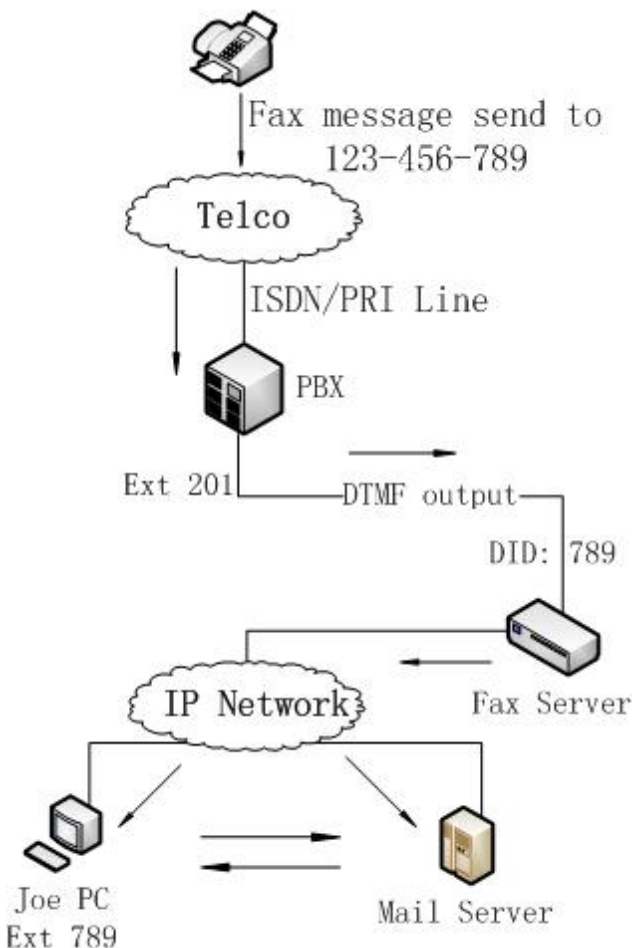

Fig. 1 Single Line Diagram (PSTN/PBX/ISDN)

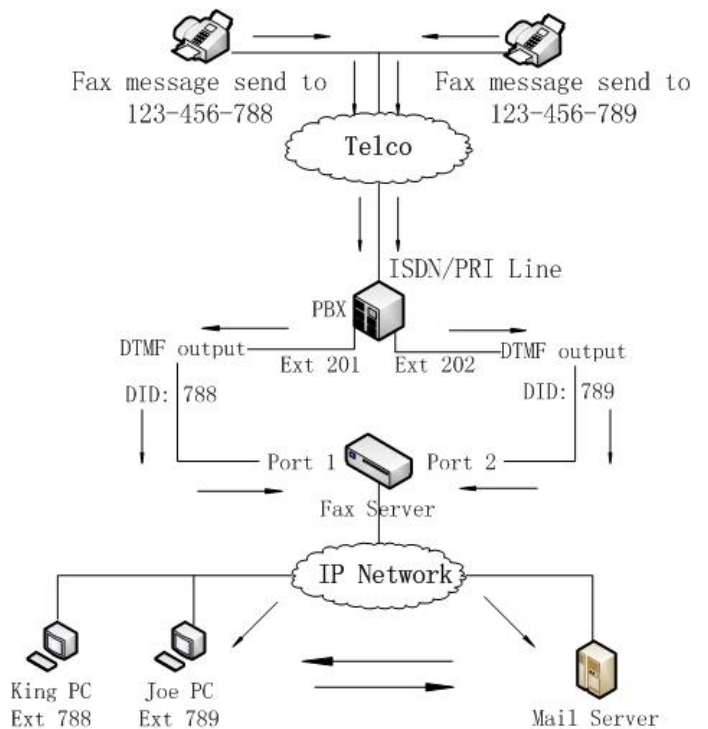

Fig. 2 Multi-Line Connection Diagram (PSTN/PBX/ISDN)

If you connect multi-Ext lines to Fax server, you can set as Automatic Switching in PBX, as Fig.2, when line 201 is busy, it will redirect to 202 automatically.

Step 1. Try it with your normal fax line and make sure you can receive fax via the extension number

Implement Step1 is in order to ensure whether the extension number can receive faxes. As Fig.3 shows, after user dial extension 788, King will receive the fax.

For example:

	Name	Login ID	Department	Ext	Line
<input type="checkbox"/>	King	King	Default	788	Custom
<input type="checkbox"/>	joe	joe	Default	789	Custom

Fig.3 User Information

1. Plug one end of the PSTN cable into the myFAX's LINE jack, and the other into the port on a normal fax machine

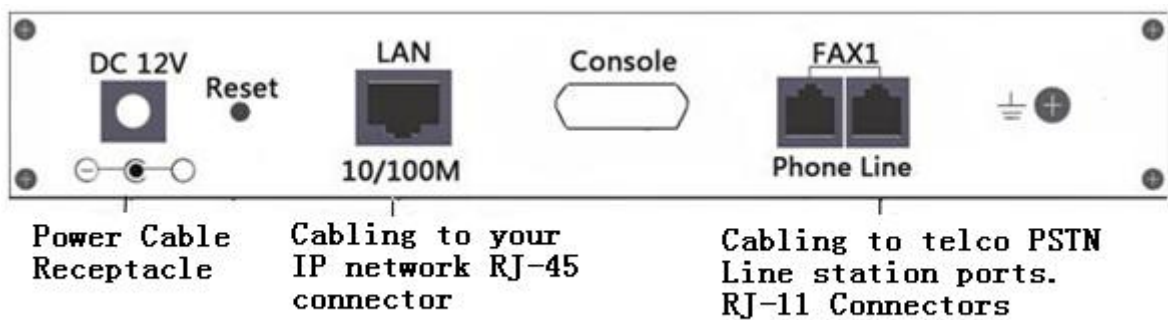

Fig4. myFAX Back Panel

2. Active Receiving Voice(DID) under myFAX system→Server Setting→Line
3. Dial extension number, when you hear the voice prompt. Then input the extension: 123 on the normal fax machine
4. After you hear the fax tone, press **send** on your fax machine to make sure user is able to receive fax in private inbox.

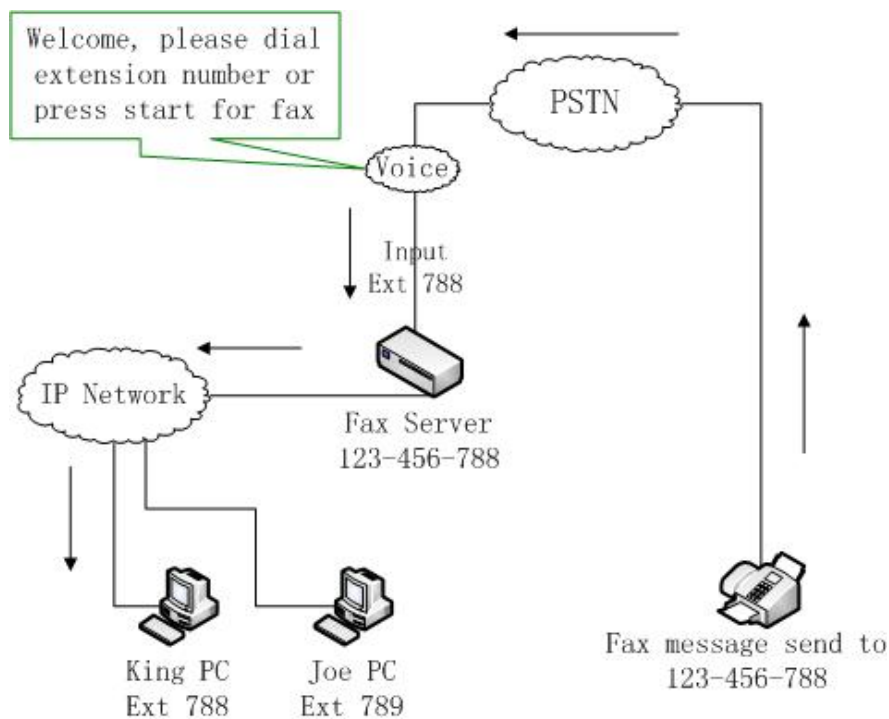

Fig.5 DTMF Receiving

Flow Diagram of fax sending:

Step1: Dial fax number eg.123-456-788

Step2: Hear receiving voice

Step3: Input extension number(788)

Step4: After hear fax signal, press START to send fax

Step5: Begin to transmit

Step6: Done

Step2. Try it with PBX

After confirm Step1, then try step2 and configure DID function.

Notice:

1. Make sure do not tick "Extension Required". It will force the system to only accept correct extension. May cause you never receive fax in the testing stage.
2. We have "DID Debugging" in line setting. This will show the received DTMF from your input. But remember to turn it off after use.

Operate as follows:

1. Connecting to myFAX with PSTN Line
2. Active **Receiving Voice(DID)** under myFAX system→Server Setting→Line
3. Active "**DID Debugging**" under line setting
4. Use a normal fax machine to send a fax to myFAX fax server, then view Debugging Log to check if you have received the DID number sent from PBX.
5. Configuring myFAX for Inter-Operation

Receiving Param	Max Pages:	<input type="text" value="25"/>	Rings:	<input type="text" value="3"/>
	Receiving Voice(DID):	<input checked="" type="checkbox"/>	Volume:	<input type="text" value="Default"/>
	Play Times:	<input type="text" value="1"/>	CID Mode:	<input type="text" value="DTMF"/>
Sending Param	Sending Voice:	<input type="checkbox"/>	Volume:	<input type="text" value="Default"/>
	Tagline:	<input checked="" type="checkbox"/>		
Identifier	Fax Number:	<input type="text" value="123456"/>	CSID (ASCII):	<input type="text" value="FaxServer"/>
	Extension:	<input type="text" value="3"/>	Extension Required:	<input type="checkbox"/>
	Prefix Strip:	<input type="text" value="1"/>	Suffix Strip:	<input type="text" value="2"/>
	DID Debugging:	<input checked="" type="checkbox"/> Report		

Fig.6 Line Setting

Receiving Voice(DID)	Enable Receiving Voice(DID) Set Receiving Voice as Silence. Login myFAX, go to Server Setting→Voice Voice Language: <input type="text" value="Silence"/> <input type="button" value="Save"/> Under Silence mode, after answer the call, there is no voice to prompt you to input extension.
Extension	Extension correspond to each user on fax server
Extension Required	Required the correct extension, otherwise cannot send fax
Prefix Strip	Strip the prefix of incoming DTMF
Suffix Strip	Strip the suffix of incoming DTMF
DID Debugging	Received log of extension number test (This function is used for test. Please turn it off after test)
Report	View the DTMF receiving report
Total Digit= Prefix + Extension + Suffix	

Example of Prefix Strip and Suffix Strip:

Fax server user name	Ext.
King	788

Line Setting:

Prefix Strip	Suffix Strip
1	2

As the above setting, if the incoming call is: 8123#9, strip the prefix 1 digital (8), strip the suffix 2 digitals (#9), and retain 123

DID Debugging:

Date&Time	Device	Input	Prefix	Ext	Suffix	Errno
2009-03-20 11:43:21	ttyS4	6:6:8788#9	1:1:8	3:3:123	2:2:#9	0:PASS

Date&Time	Device	Input	Prefix	Ext	Suffix	Errno
Receiving Time	Line	Original extension(8788#9)	Strip prefix 1 digital(8)	Retain valid extension(788)	Strip suffix 2 digitals (#9)	No error

Error Messages:

Errno	Description
0:PASS	No error
START SIGNAL	After answer the call, press start button but inputting extension
EXT TIMEOUT	Timeout waiting for complete extension digit.
NO INPUT	No extension number

FAQ

- 1. Q: When I test sending fax to an extension, why the fax is delivered to Inbox?
A: First, please check your Extension is corresponding to the Ext of user; second, enable DID Debugging to check whether the fax server has received the DTMF.

- 2. Q: For example: I received DTMF"##789*&^%", and the "789" is extension, then how do I to configure the server.
A: First, set the Extension as 3(Extension digits), under Line Setting in fax server; second, set the Prefix Strip as 2(strip the first 2 digits), Suffix Strip as 4(strip the last 4 digits). Like Fig7.

Identifier	Fax Number:	<input type="text" value="123456"/>	CSID (ASCII):	<input type="text" value="FaxServer"/>
	Extension:	<input type="text" value="3"/>	Extension Required:	<input type="checkbox"/>
	Prefix Strip:	<input type="text" value="2"/>	Suffix Strip:	<input type="text" value="4"/>
	DID Debugging:	<input type="checkbox"/>		

Fig.7 Line Setting

- 3. Q: Should I enable **DID Debugging** and **Extension Required** when I use the fax server ordinarily?
A: No, only when you test whether it can receive DTMF, it is necessary to enable **DID Debugging**. **Extension Required** request user must input correct extension when send fax, otherwise it will disconnect dialing call. Whether use this function depends on customer-need.

EDVAC Information Systems Limited

2/F, Chengxi Building, Sha Tou, Chang An,
Dong Guan, Guang Dong,
China
Tel: +86 (769) 8568-3770 / 8530-1101
Fax: +86 (769) 8530-1102
Email: info@myfaxoa.com



www.myfaxoa.com